

PWC FIT CHART

ISA BOW STOP

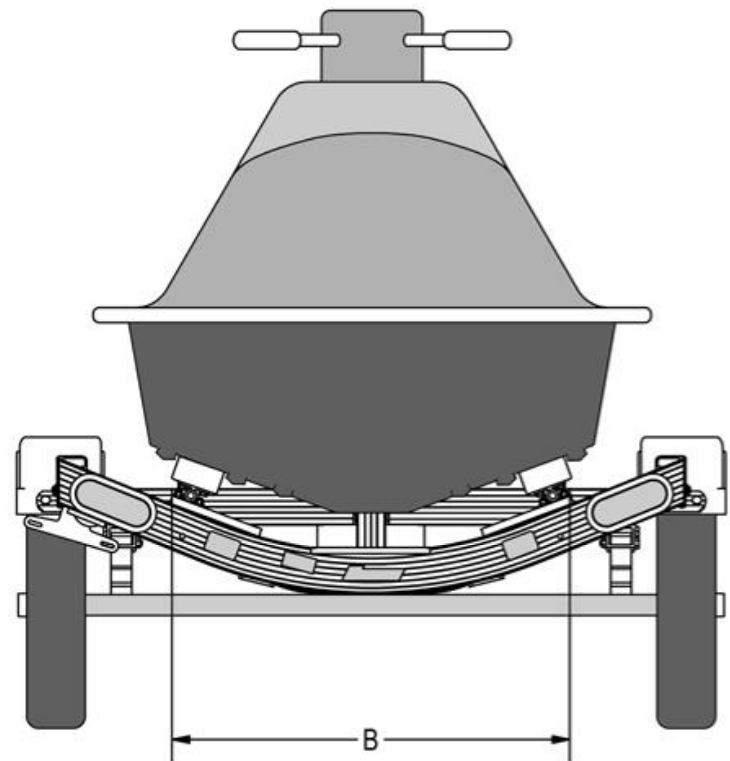
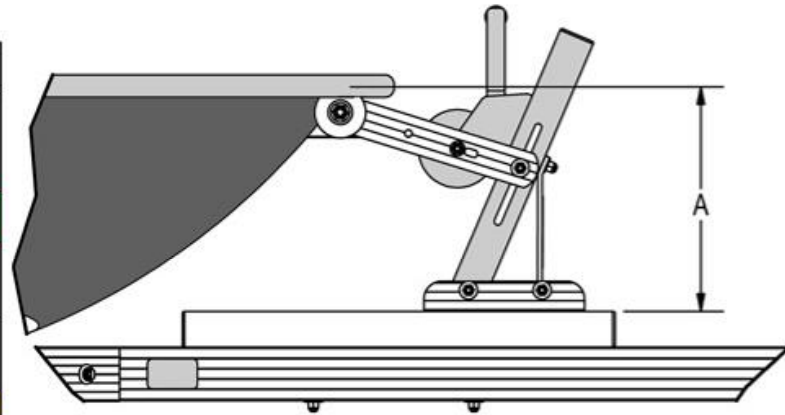

APPROX. POSITION ON TRAILER

MODELS	APPROX. POSITION ON TRAILER			
	LTWCI	LTWCI	LTWCII ELITE WCII WC2-2	LTWCII ELITE WCII WC2-2
KAWASAKI	BOW STOP	BUNKS	BOW STOP	BUNKS
STX	17-18"	25"	17-18"	25"
ULTRA	17-18"	25"	17-18"	25"
SEA-DOO	BOW STOP	BUNKS	BOW STOP	BUNKS
Spark	12-13"	24"	13-14"	24"
GTS/GTR/GTI/ WAKE155	14-15"	27"	15-16"	27"
RXT/GTX/ WAKE215	15-16"	27"	16-17"	27"
RXP	15-16"	27"	16-17"	27"
YAMAHA	BOW STOP	BUNKS	BOW STOP	BUNKS
VX/ VXR/VXS	14-15"	25"	15-16"	25"
FX/FZS/FZR	14-15"	25"	15-16"	25"

MODELS	LXT	LXT
SEA-DOO	BOW STOP	BUNKS
Spark	12-13"	24"

LXT TRAILER HAS REGULAR BOW STOP

THESE MEASUREMENTS ARE MEANT TO BE A GUIDE TO SETUP A 2014 TRITON LTWCI OR TWO PLACE MODELS WITH THE NEW ISA BOW STOP. THIS DOES NOT INCLUDE THE LXT MODEL WHICH HAS THE REGULAR BOW STOP. THESE ARE APPROXIMATE POSITIONS FOR THE STATED PWC'S. MAKE SURE THAT THE POSITION OF THE BUNKS ARE BETWEEN THE OUTER CHINES OF THE HULL. PWC POSITION ON THE TRAILER FRONT TO BACK SHOULD ACHIEVE A TONGUE WEIGHT OF 7-10% OF THE TOTAL GROSS WEIGHT OF THE TRAILER PACKAGE FOR THE BEST TOWING EXPERIENCE.
(GAS+GEAR+PWC'S+TRAILER WEIGHT=GROSS)