

M	15457	LJW	02-02-12	UPDATED PRINT PER NEW STANDARD
L	15424	KMH	12-02-11	44.00" FENDER DIMENSION (E) WAS 62.00"
DWG. REV.	ECR/NDR NUMBER	REVISED BY	DATE	DESCRIPTION

ALL DIMENSIONS ARE IN INCHES  
UNLESS OTHERWISE STATED  
TOLERANCES EXCEPT AS NOTED  
DECIMALS:  
.X ±0.100  
.XX ±0.060  
.XXX ±0.030  
.XXXX ±0.010  
ANGLES:  
±1°  
ALL FORMED ANGLES  
EQUAL 90° UNLESS  
NOTED OTHERWISE  
( ) INDICATES REFERENCE

THE INFORMATION IN THIS DRAWING IS THE SOLE  
PROPERTY OF KARAVAN TRAILERS, INC. ANY  
REPRODUCTION IN PART OR WHOLE WITHOUT  
THE WRITTEN PERMISSION OF KARAVAN TRAILERS,  
INC. IS PROHIBITED.  
APPROVED BY: ---  
DRAWN BY: MJ HALFMANN  
DATE: 11/12/2007  
SHEET: 1 OF 7  
SCALE: N/A

**KARAVAN**  
TRAILERS  
TITLE: KDP-1820-17/22/27-SPRING  
MAT'L: SEE B.O.M.  
FINISH: N/A  
DWG. #: KDP-1820-17-22-27-SPRING

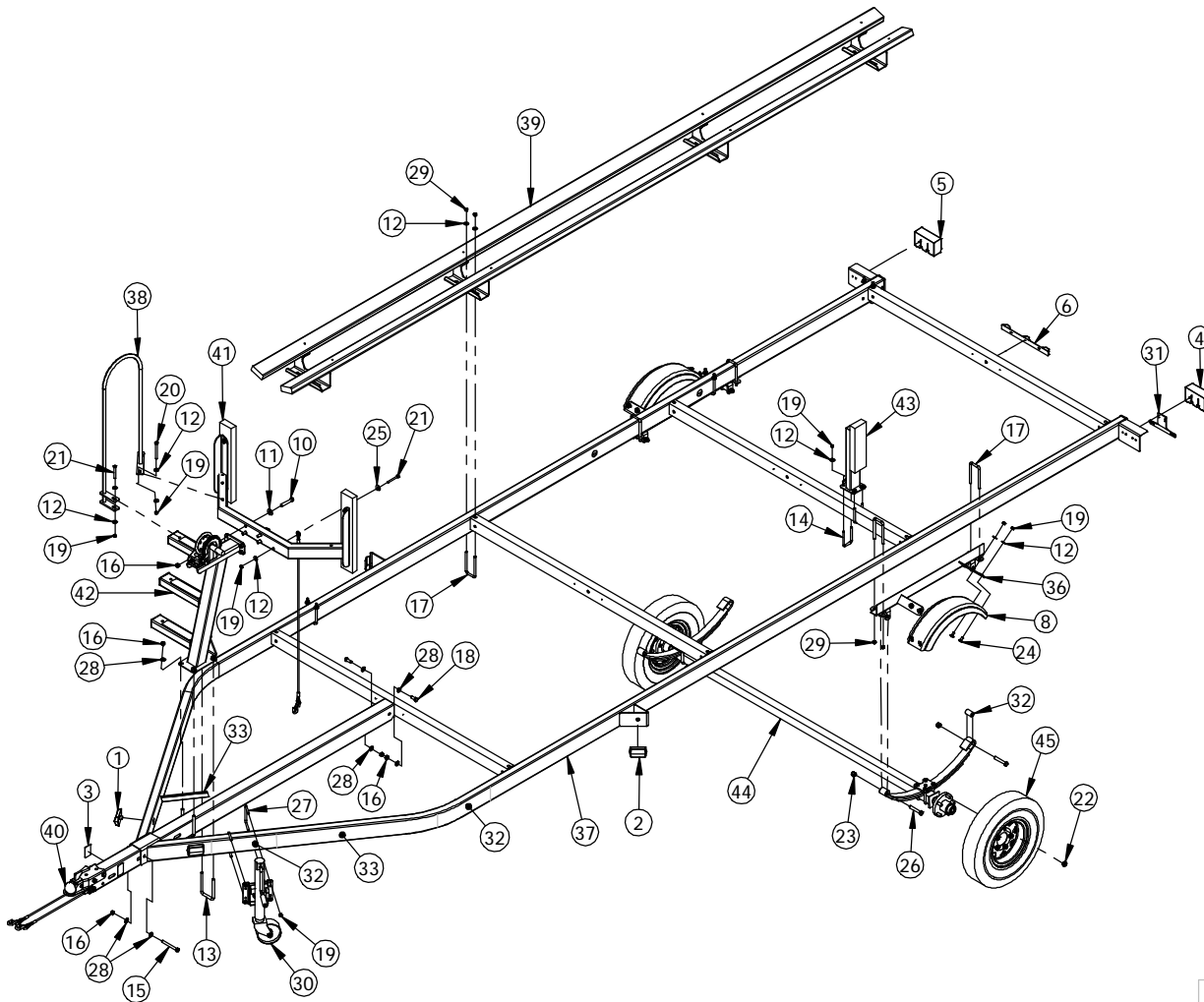

ITEM NO.	SEE NOTES	PART NUMBER	DESCRIPTION	QTY.
1		205-00105	AMBER SIDE LIGHT	2
2	2	205-00106	AMBER SIDE LIGHT	2
3		205-00142	AMBER REFLECTOR TAPE	2
4	2	205-00157	TAIL LIGHT LH	1
5	2	205-00158	TAIL LIGHT R.H.	1
6	2	205-00163	I.D. BAR LIGHT SUBM.	1
7	2	205-00170	WIRE HARNESS	1
8		206-00039	FENDER	2
9		208-00046	SAFETY CABLE & HOOK	1
10		210-00012	.50"-13 X 3.00" HX HD BOLT	4
11		210-00017	.50" FLAT WASHER	4
12		210-00025	.375" FLAT WASHER	39
13		210-00030	.50"-13 X 3.063" X 5.25" U-BOLT	2
14		210-00031	.375"-16 X 2.031" X 3.75" U-BOLT	4
15		210-00040	.50"-13 X 4.50" HX HD BOLT	1
16		210-00061	.50"-13 CENTERLOCK HEX NUT	11
17		210-00068	.438"-14 X 2.25" X 5.31" U-BOLT	12
18		210-00072	.50"-13 X 1.25" HX HD BOLT	2
19		210-00076	.375"-16 CENTERLOCK HEX NUT	24
20		210-00080	.375"-16 X 4.00" HX HD BOLT	2
21		210-00089	.375"-16 X 3.00" HX HD BOLT	2
22		210-00137	.50"-20 X .813" LUG NUT	10
23		210-00157	.563"-12 NYLOCK HEX NUT	4
24		210-00194	.375"-16 X .875" CARRIAGE BOLT	8
25		210-00207	.375" FLAT WASHER	1
26		210-00211	.563"-12 X 3.25" HX HD BOLT	4
27		210-00231	.375"-16 X 3.00" X 4.06" U-BOLT	2
28		210-00240	.50" SAE FLAT WASHER ZINC	10
29		210-00330	.438"-14 CENTERLOCK HEX NUT	24
30	1	214-00008	TONGUE JACK	1
31		229-00006	LICENSE PLATE BRACKET	1
32		229-00095	BUSHING	2
33		234-00032	TRAILERING CHECKLIST	1
34		234-00058	LOGO	4
35		234-00060	LOGO	2
36	1	300-00953	SPRING HANGER	2
37		300-01609	FRAME WELDMENT	1
38		300-01673	HAND RAIL WELD	1
39	3	310-01885	BUNK ASSY	2
40	3	310-01891	TONGUE ASSY.	1
41		310-02017	WINCH BOARD ASSY	1
42	1	310-02018	WINCH ASSY.	1
43	3	310-02292	GUIDE-ON ASSY.	2
44	1	AXLE ASSY	SEE OPTIONS	1
45	1	TIRE	5-HOLE TIRE & RIM	2

NOTES:

- 1.) SEE OPTIONS ON PAGE THREE.
- 2.) SEE ADDITIONAL INSTRUCTIONS ON PAGE FOUR.
- 3.) SEE ADDITIONAL INSTRUCTIONS ON PAGE SEVEN.

M	15457	LJW	02-02-12	UPDATED PRINT PER NEW STANDARD
L	15424	KMH	12-02-11	44.00" FENDER DIMENSION (E) WAS 62.00"
DWG. REV.	ECR/NDR NUMBER	REVISED BY	DATE	DESCRIPTION

ALL DIMENSIONS ARE IN INCHES UNLESS OTHERWISE STATED TOLERANCES EXCEPT AS NOTED DECIMALS:

.X ±0.100  
 .XX ±0.060  
 .XXX ±0.030  
 .XXXX ±0.010

ANGLES: ±1°

ALL FORMED ANGLES EQUAL 90° UNLESS NOTED OTHERWISE

( ) INDICATES REFERENCE

THE INFORMATION IN THIS DRAWING IS THE SOLE PROPERTY OF KARAVAN TRAILERS, INC. ANY REPRODUCTION IN PART OR WHOLE WITHOUT THE WRITTEN PERMISSION OF KARAVAN TRAILERS.

APPROVED BY:

---

DRAWN BY:

MJ HALFMANN

DATE:

11/12/2007

SHEET:

2 OF 7

SCALE:

NA

**KARAVAN**  
TRAILERS

TITLE:

KDP-1820-17/22/27-SPRING

MAT'L:

SEE B.O.M.

FINISH:

NA

DWG. #:

KDP-1820-17-22-27-SPRING

HORIZONTAL GUIDE ON OPTION

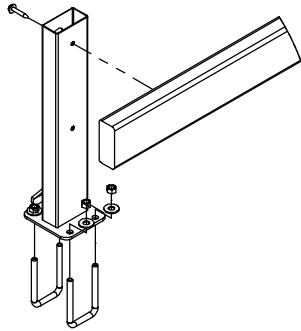

PLASTIC BUNK OPTIONS

- 2" X 4" X 192"
- 2" X 4" X 96" (TWO PER SIDE)
- 2" X 4" X 108" (TWO PER SIDE)
- 2" X 6" X 192"
- 2" X 6" X 96" (TWO PER SIDE)
- 2" X 6" X 108" (TWO PER SIDE)
- 2" X 6" X 120" (TWO PER SIDE)

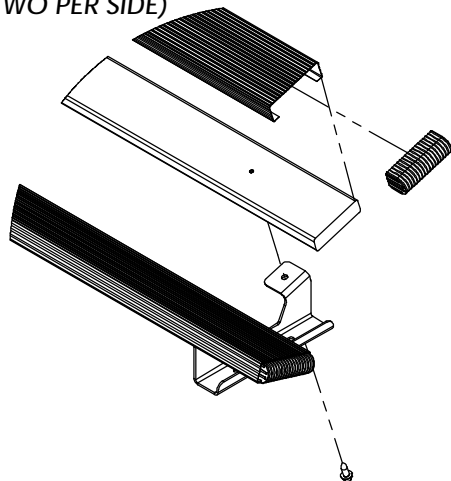

TONGUE TUBE OPTIONS

- 3" X 5" X 118"
- 3" X 5" X 142"

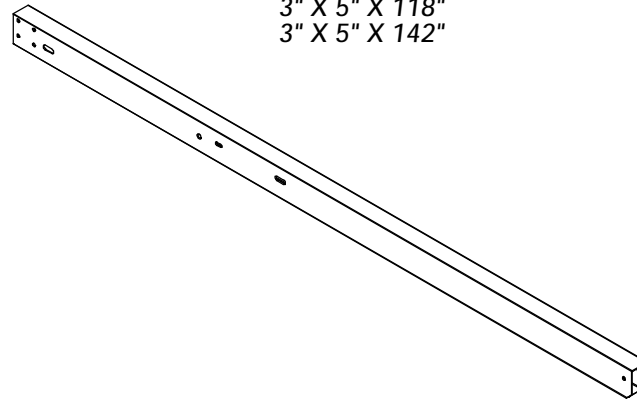

TRI-TOON KIT OPTION

- 2" X 4" CARPET
- 2" X 4" PLASTIC
- 2" X 6" CARPET
- 2" X 6" PLASTIC

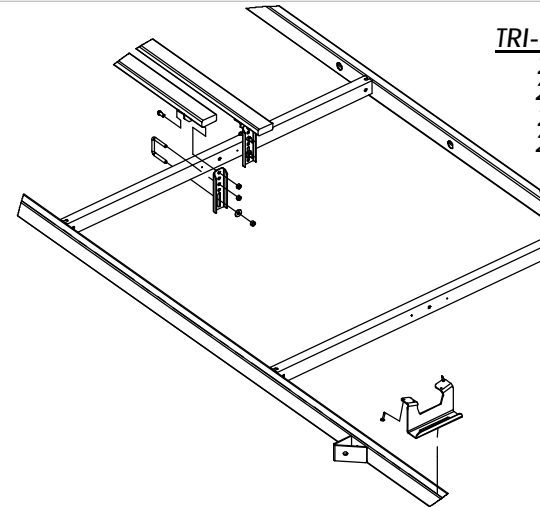

CARPET BUNK OPTIONS

- 2" X 4" X 96" (TWO PER SIDE)
- 2" X 4" X 108" (TWO PER SIDE)
- 2" X 6" X 192"
- 2" X 6" X 96" (TWO PER SIDE)
- 2" X 6" X 108" (TWO PER SIDE)
- 2" X 6" X 120" (TWO PER SIDE)

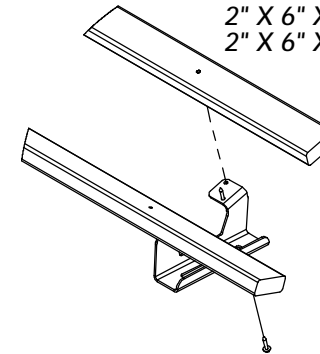

ALL DIMENSIONS ARE IN INCHES  
UNLESS OTHERWISE STATED  
TOLERANCES EXCEPT AS NOTED  
DECIMALS:  
.X ±0.100  
.XX ±0.060  
.XXX ±0.030  
.XXXX ±0.010  
ANGLES:  
±1°  
ALL FORMED ANGLES  
EQUAL 90° UNLESS  
NOTED OTHERWISE  
( ) INDICATES REFERENCE

THE INFORMATION IN THIS DRAWING IS THE SOLE  
PROPERTY OF KARAVAN TRAILERS, INC. ANY  
REPRODUCTION IN PART OR WHOLE WITHOUT  
THE WRITTEN PERMISSION OF KARAVAN TRAILERS,  
INC. IS PROHIBITED.  
APPROVED BY: ---  
DRAWN BY: MJ HALFMANN  
DATE: 11/12/2007  
SHEET: 3 OF 7  
SCALE: N/A

**KARAVAN**  
TRAILERS

TITLE: KDP-1820-17/22/27-SPRING

MAT'L: SEE B.O.M.

FINISH: N/A

DWG. #: KDP-1820-17-22-27-SPRING

M	15457	LJW	02-02-12	UPDATED PRINT PER NEW STANDARD
L	15424	KMH	12-02-11	44.00" FENDER DIMENSION (E) WAS 62.00"
DWG. REV.	ECR/NDR NUMBER	REVISED BY	DATE	DESCRIPTION

VIEW A  
GREEN & WHITE WIRES RUN  
DOWN RIGHT SIDE TUBE.

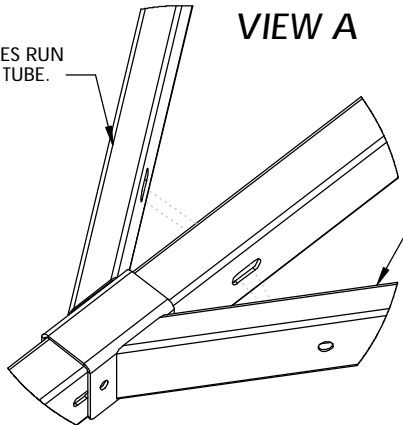

YELLOW WIRE RUNS  
DOWN LEFT SIDE TUBE.

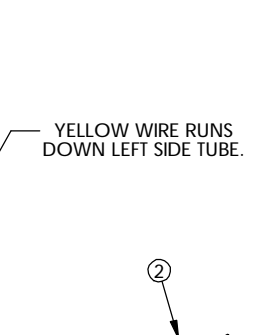

THE TAIL LIGHT IS  
MOUNTED TO THE CENTER  
HOLES OF THE TAIL  
LIGHT BRACKET.

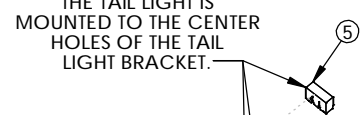

THE TAIL LIGHT IS  
MOUNTED TO THE CENTER  
HOLES OF THE TAIL  
LIGHT BRACKET.

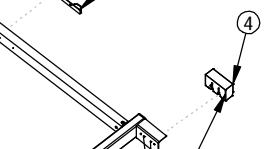

VIEW B

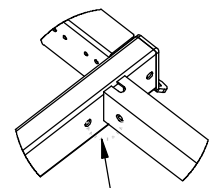

ID BAR WIRE

WIRE HARNESS



ALL DIMENSIONS ARE IN INCHES  
UNLESS OTHERWISE STATED  
TOLERANCES EXCEPT AS NOTED  
DECIMALS:  
.X ±0.100  
.XX ±0.060  
.XXX ±0.030  
.XXXX ±0.010  
ANGLES:  
±1°  
ALL FORMED ANGLES  
EQUAL 90° UNLESS  
NOTED OTHERWISE  
( ) INDICATES REFERENCE

THE INFORMATION IN THIS DRAWING IS THE SOLE  
PROPERTY OF KARAVAN TRAILERS, INC. ANY  
REPRODUCTION IN PART OR WHOLE WITHOUT  
THE WRITTEN PERMISSION OF KARAVAN TRAILERS,  
INC. IS PROHIBITED.  
APPROVED BY: ---  
DRAWN BY: MJ HALFMANN  
DATE: 11/12/2007  
SHEET: 4 OF 7  
SCALE: N/A

**KARAVAN**  
TRAILERS  
TITLE: KDP-1820-17/22/27-SPRING  
MAT'L: SEE B.O.M.  
FINISH: N/A  
DWG. #KDP-1820-17-22-27-SPRING

M	15457	LJW	02-02-12	UPDATED PRINT PER NEW STANDARD
L	15424	KMH	12-02-11	44.00" FENDER DIMENSION (E) WAS 62.00"
DWG. REV.	ECR/NDR NUMBER	REVISED BY	DATE	DESCRIPTION

MODEL #	DIMENSIONS		
	"D"	"E"	"P"
*	230.2	47.25	32.0

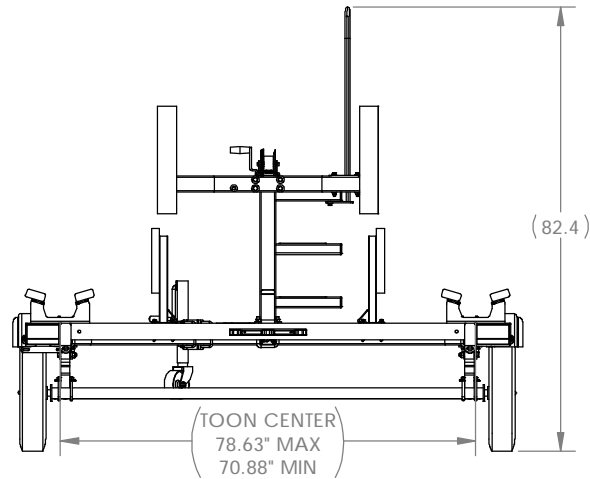
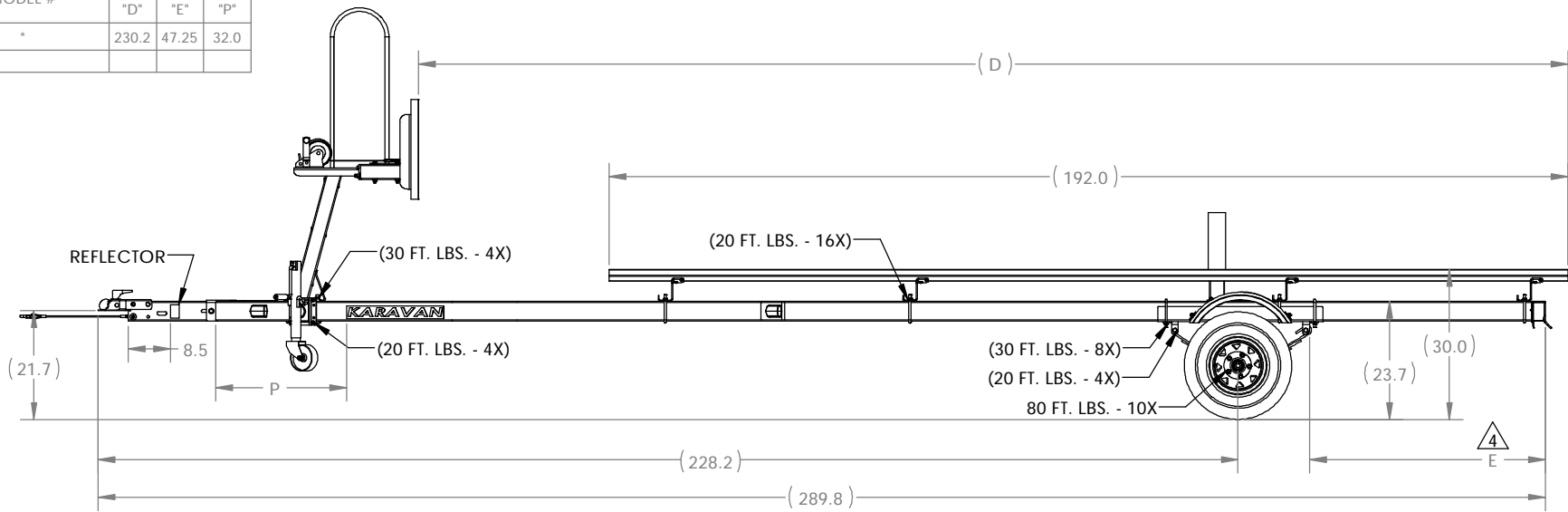

NOTES:

4 DIMENSION IS FROM THE BACK OF THE SPRING HANGER TO THE BACK OF THE FRAME.

5.) TORQUE CALLOUTS IN PARENTHESIS ARE FOR REFERENCE. TIGHTEN FASTENERS UNTIL PINCHED TIGHT (DO NOT OVER TIGHTEN BUNK PIVOT POINTS). MINOR DEFLECTION OF MATERIAL IS ACCEPTABLE

M	15457	LJW	02-02-12	UPDATED PRINT PER NEW STANDARD
L	15424	KMH	12-02-11	44.00" FENDER DIMENSION (E) WAS 62.00"
DWG. REV.	ECR/NDR NUMBER	REVISED BY	DATE	DESCRIPTION

ALL DIMENSIONS ARE IN INCHES UNLESS OTHERWISE STATED TOLERANCES EXCEPT AS NOTED DECIMALS:  
 .X ±0.100  
 .XX ±0.060  
 .XXX ±0.030  
 .XXXX ±0.010  
 ANGLES:  
 ±1°  
 ALL FORMED ANGLES EQUAL 90° UNLESS NOTED OTHERWISE  
 ( ) INDICATES REFERENCE

THE INFORMATION IN THIS DRAWING IS THE SOLE PROPERTY OF KARAVAN TRAILERS, INC. ANY REPRODUCTION IN PART OR WHOLE WITHOUT THE WRITTEN PERMISSION OF KARAVAN TRAILERS, INC. IS PROHIBITED.  
 APPROVED BY: ---  
 DRAWN BY: M.J. HALFMANN  
 DATE: 11/12/2007  
 SHEET: 5 OF 7  
 SCALE: N/A

**KARAVAN**  
TRAILERS

TITLE: KDP-1820-17/22/27-SPRING  
 MAT'L: SEE B.O.M.  
 FINISH: N/A  
 DWG. #: KDP-1820-17-22-27-SPRING



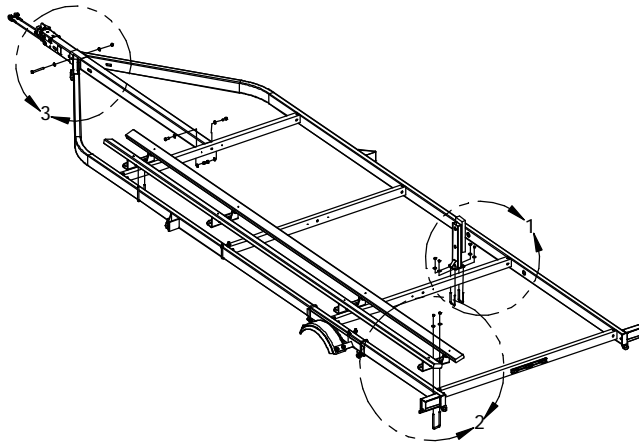

**GUIDE-ON MOUNTING INSTRUCTIONS**

**VIEW 1**

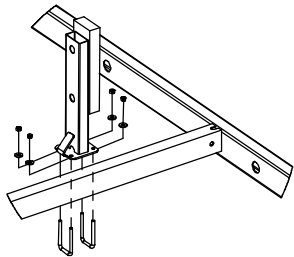

**BUNK MOUNTING INSTRUCTIONS**

**VIEW 2**

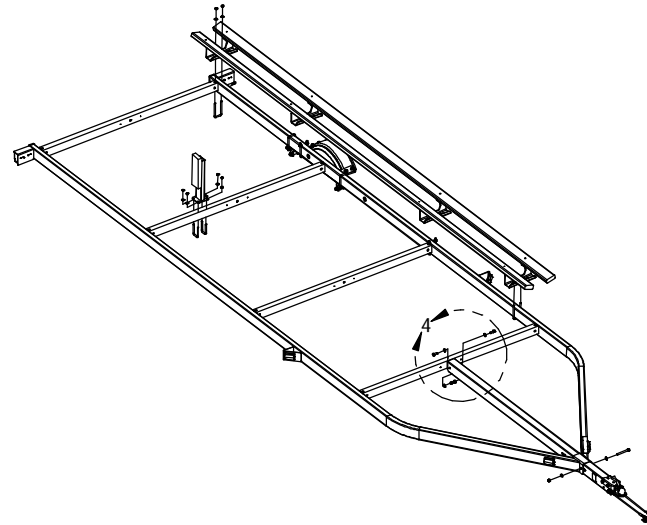
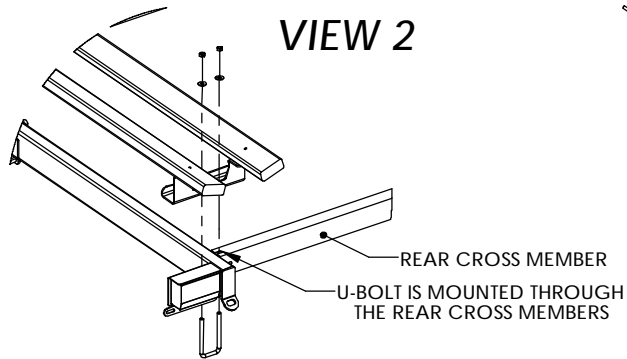

**TONGUE MOUNTING INSTRUCTIONS**

**VIEW 3**

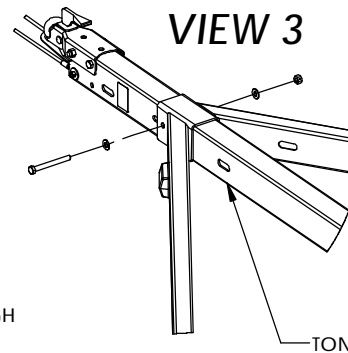

**VIEW 4**

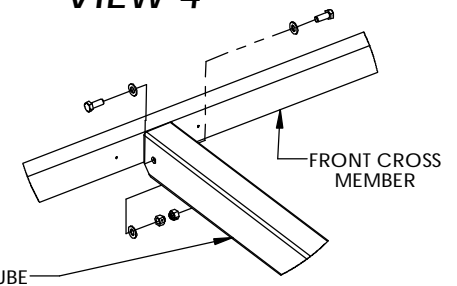

M	15457	LJW	02-02-12	UPDATED PRINT PER NEW STANDARD
L	15424	KMH	12-02-11	44.00" FENDER DIMENSION (E) WAS 62.00"
DWG. REV.	ECR/NDR NUMBER	REVISED BY	DATE	DESCRIPTION

ALL DIMENSIONS ARE IN INCHES UNLESS OTHERWISE STATED TOLERANCES EXCEPT AS NOTED DECIMALS:

.X ±0.100  
 .XX ±0.060  
 .XXX ±0.030  
 .XXXX ±0.010

ANGLES: ±1°

ALL FORMED ANGLES EQUAL 90° UNLESS NOTED OTHERWISE

( ) INDICATES REFERENCE

THE INFORMATION IN THIS DRAWING IS THE SOLE PROPERTY OF KARAVAN TRAILERS, INC. ANY REPRODUCTION IN PART OR WHOLE WITHOUT THE WRITTEN PERMISSION OF KARAVAN TRAILERS, INC. IS PROHIBITED.

APPROVED BY: ---

DRAWN BY: MJ HALFMANN

DATE: 11/12/2007

SHEET: 7 OF 7

SCALE: N/A

**KARAVAN TRAILERS**

TITLE: KDP-1820-17/22/27-SPRING

MAT'L: SEE B.O.M.

FINISH: N/A

DWG. #: KDP-1820-17-22-27-SPRING